

Parts needed to mount the KIDES-DUO extrusion

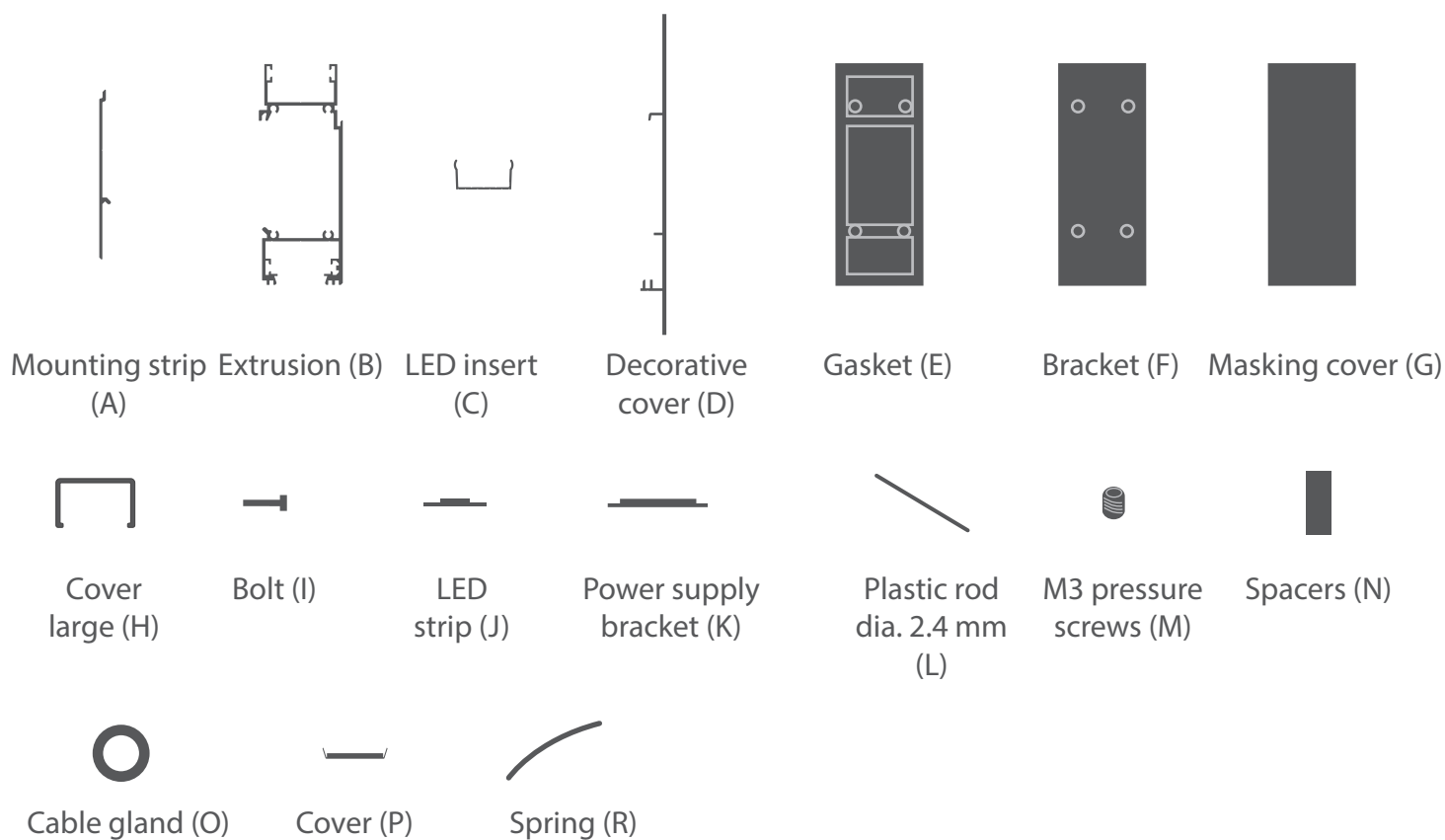

Tools needed for mounting:

- drill
- screwdriver
- screws
- metal saw
- angle grinder / milling machine

NOTE! All LED strips must be connected to a 12 V or 24 V power supply.

IMPORTANT: The manual presents the simplest mounting procedure.
More mounting procedures and related accessories can be found at klusdesign.eu

1. Drill holes in the mounting strip (A) (min. two) and for the gland. Drill holes in the extrusion (B) and the LED insert (C) to run the power cables.

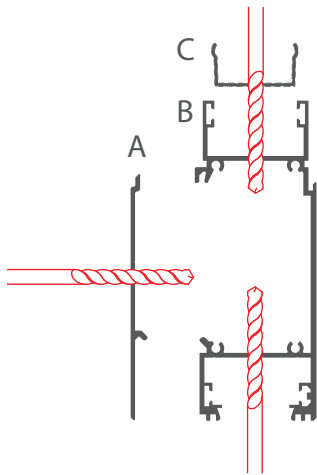

2. Insert the cable gland (O) and the spacers (N) into the holes in the mounting strip (A).

cross-section

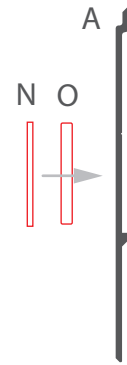

side view



3. Attach the mounting strip (A) to the mounting surface with screws suitable for the mounting surface. Run the cable out through the gland.

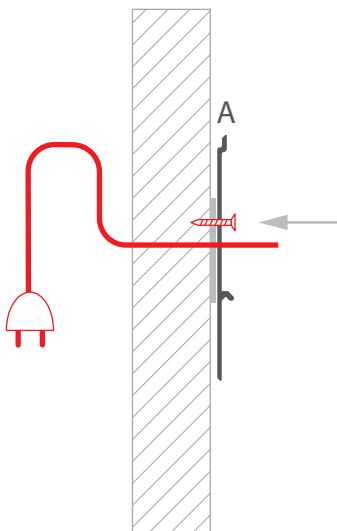

4. Mount the LED strips (J), lead out the cable and insert the covers (H, P) in the extrusion (B). Place the LED insert (C) in the extrusion (B).

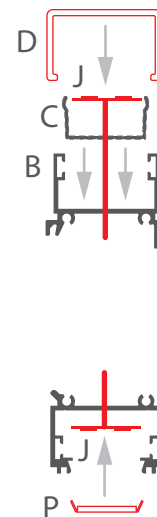

5. Attach the selected power supply to the power supply bracket (K).

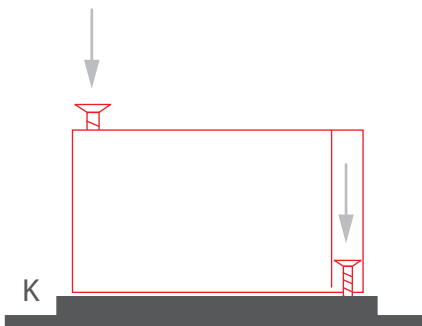

6. Insert the power supply bracket (K) in the extrusion (B).

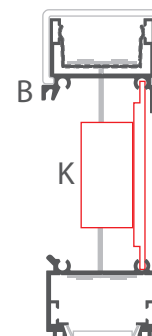

7. Secure the power supply bracket (K) by inserting one 2.4mm plastic rod (L) into the guides on each side. Cut the rods to the required length. Next secure the rods with M3 pressure screws (M), tightening them with the Allen wrench to a min. depth of 2 cm.

cross-section

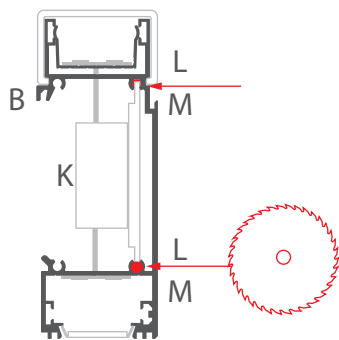

side view



8. Connect power and assemble the extrusion (B) with the mounting strip (A).

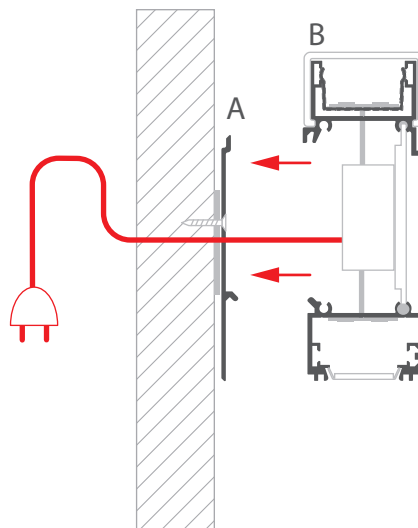

9. Insert the gaskets (E).

cross-section

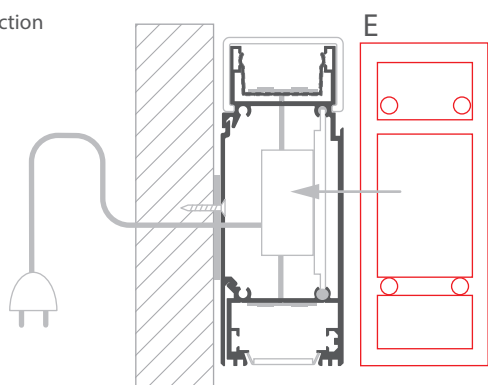

side view



10. Insert the brackets (F) into the hollows of the gaskets (E) and mount them with bolts (I).

cross-section

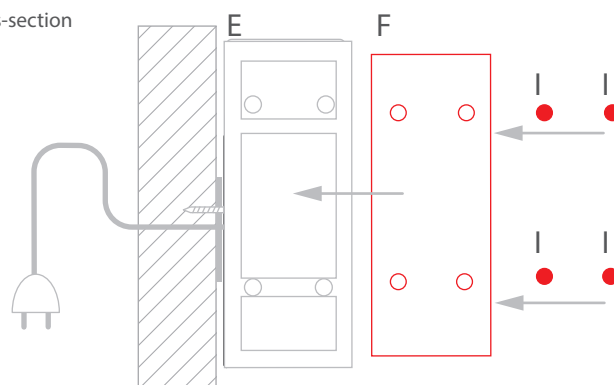

side view



11. Insert the masking cover (G) into the collar of the gaskets (E).

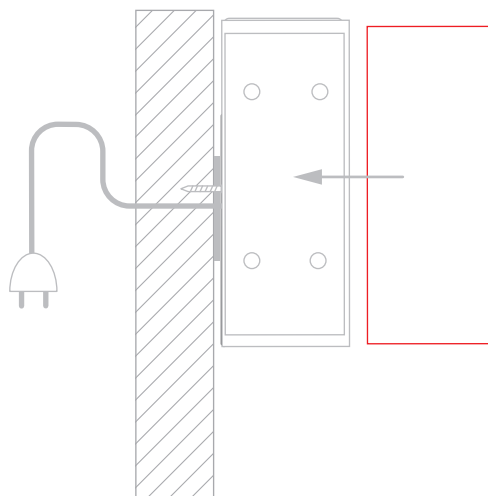

12. Install springs (R) in the marked groove (minimum two per meter) where the lower hook of the decorative cover (D) is going to mount. The number of springs should be: 2 for 1-meter long profiles, 3 for 2-meters long profiles and 4 for 3-meters long profiles. First and last spring should be placed 10-15 cm from the end of the profile.

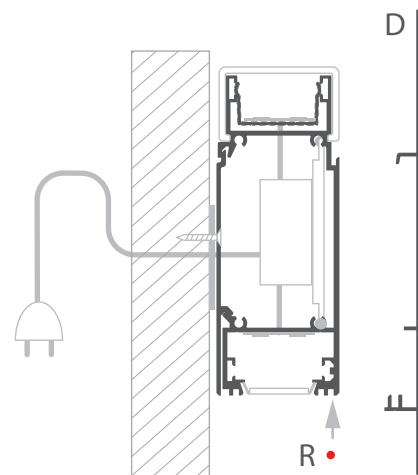

13. Mill off the hooks of the decorative cover (D) at the length that will enable you to mount it to the extrusion (B) without cutting the actual cover.

cross-section

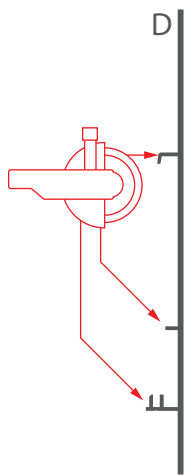

top view



14. (Optionally) Cover the surface of the diaphragm (D) with chosen lining (e.g. veneer).



15. Insert the diaphragm (D) into the extrusion (B). The spring (R) will protect it against falling off.

