

## PRODUCT DESCRIPTION

The hanger consists of two pieces with holes. Both parts should be inserted into the guide (small lock) of the selected extrusion. After insertion, they form a hanger that can be used to suspend the lighting fixture, by pulling e.g. a steel cable through it. To prevent the halves from moving in the guide, use the ZM BLOCK

Fill empty fields

Product nr.

Fixture type

Company

Job name

Date



## TECHNICAL SPECIFICATION

## TECHNICAL DRAWING

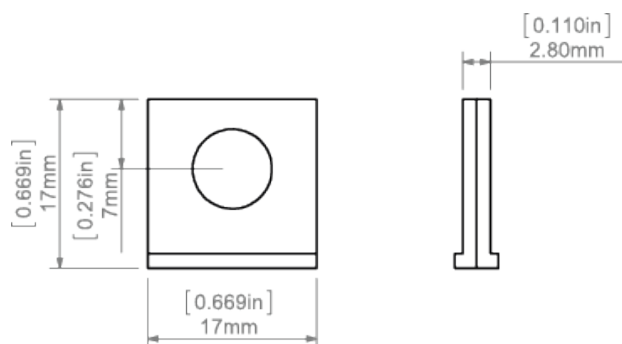

**RELATED PROFILES**

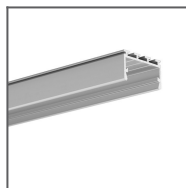

GIZA-LL profile  
Ref: C0758

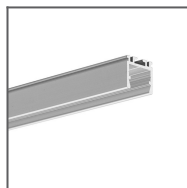

OPK-4 Profile  
Ref: C0370

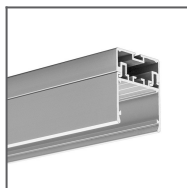

3035 Profile  
Ref: 18039



JAZ Profile  
Ref: B8547

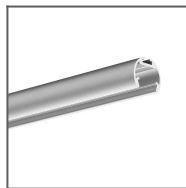

OLEK Profile  
Ref: B8505



PDS-ZM Profile  
Ref: B7696

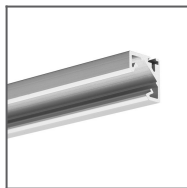

GLAD-45 Profile  
Ref: B7009



GIZA Profile  
Ref: B5556

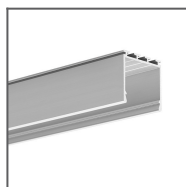

LIPOD Profile  
Ref: B5554

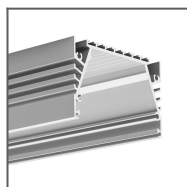

SEPOD Profile  
Ref: B6593

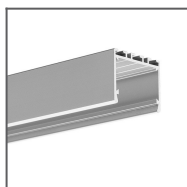

3035-O Profile  
Ref: B8441

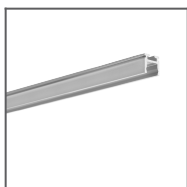

PIKO-ZM Profile  
Ref: C1168

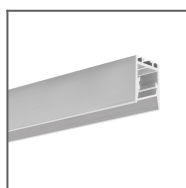

PDS-ZMG Profile  
Ref: C1418

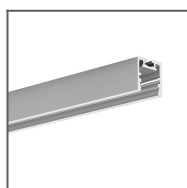

PDS-ZM-PLUS  
Profile  
Ref: C2056

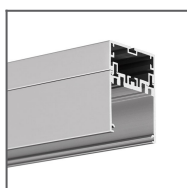

4050 Profile  
Ref: 18050

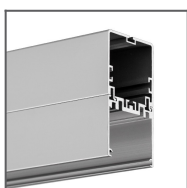

4050-W Profile  
Ref: 18051

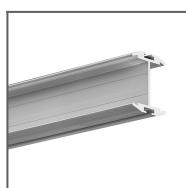

GIZA-DUO-LL  
Profile  
Ref: C2162

RELATED PRODUCTS

ACCESSORIES



Steel wire FI-1 1m  
Ref: 1397